



Processtekniska sätt att minska formförändringar vid härdning av serietillverkade kronhjul

– Erfarenheter dragna från Scantias produktionslinje

Anders Olofsson + Stefan Jonsson

Scania DX + KTH MSE



Hardening Distortions of Serial Produced Gears

Licentiatseminarium

2017-06-12, kl 14:30, Hörsalen by 260, Scania Södertälje

Licentiand Anders Olofsson

Diskussionsledare

Arne Melander Swerea Kimab

Handledare

Stefan Jonsson KTH

Julia Gerth Scania

Mål: Minimera formförändringar vid sätthärdning av transmissionskomponenter.

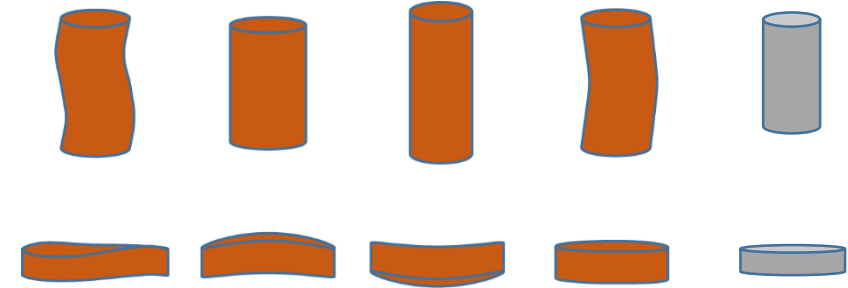
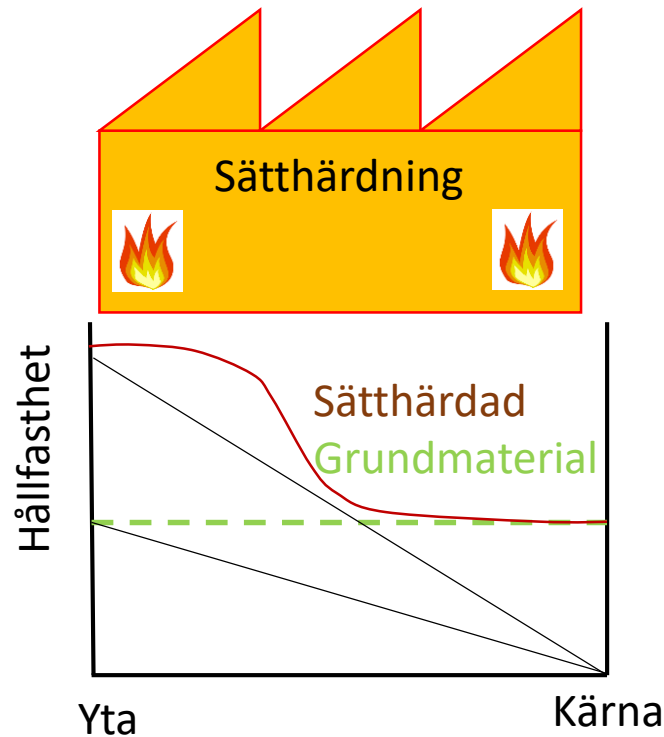
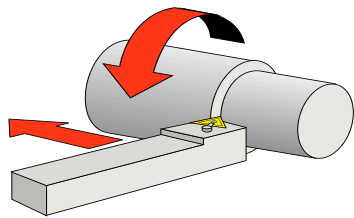
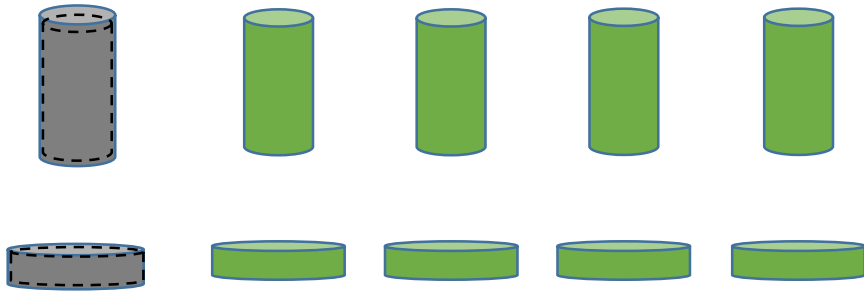

- Vad är formförändring?
 - Förändring i dimension
 - Förändring i form
 - Formförändring = förändring av dimension + förändring av form

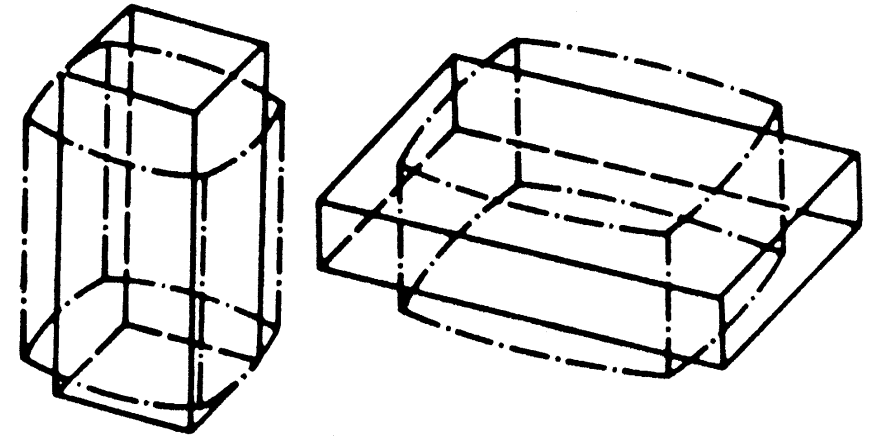

ISO 4885:2017, Ferrous materials – Heat treatments – Vocabulary

3.70

distortion

any change in the shape and original dimensions of a ferrous workpiece, occurring during *heat treatment* ([3.108](#))

Note 1 to entry: The causes are manifold including not only the heat treatment process but also the workpiece geometry, steel inhomogeneity and the production conditions.

Formförändring – många orsaker

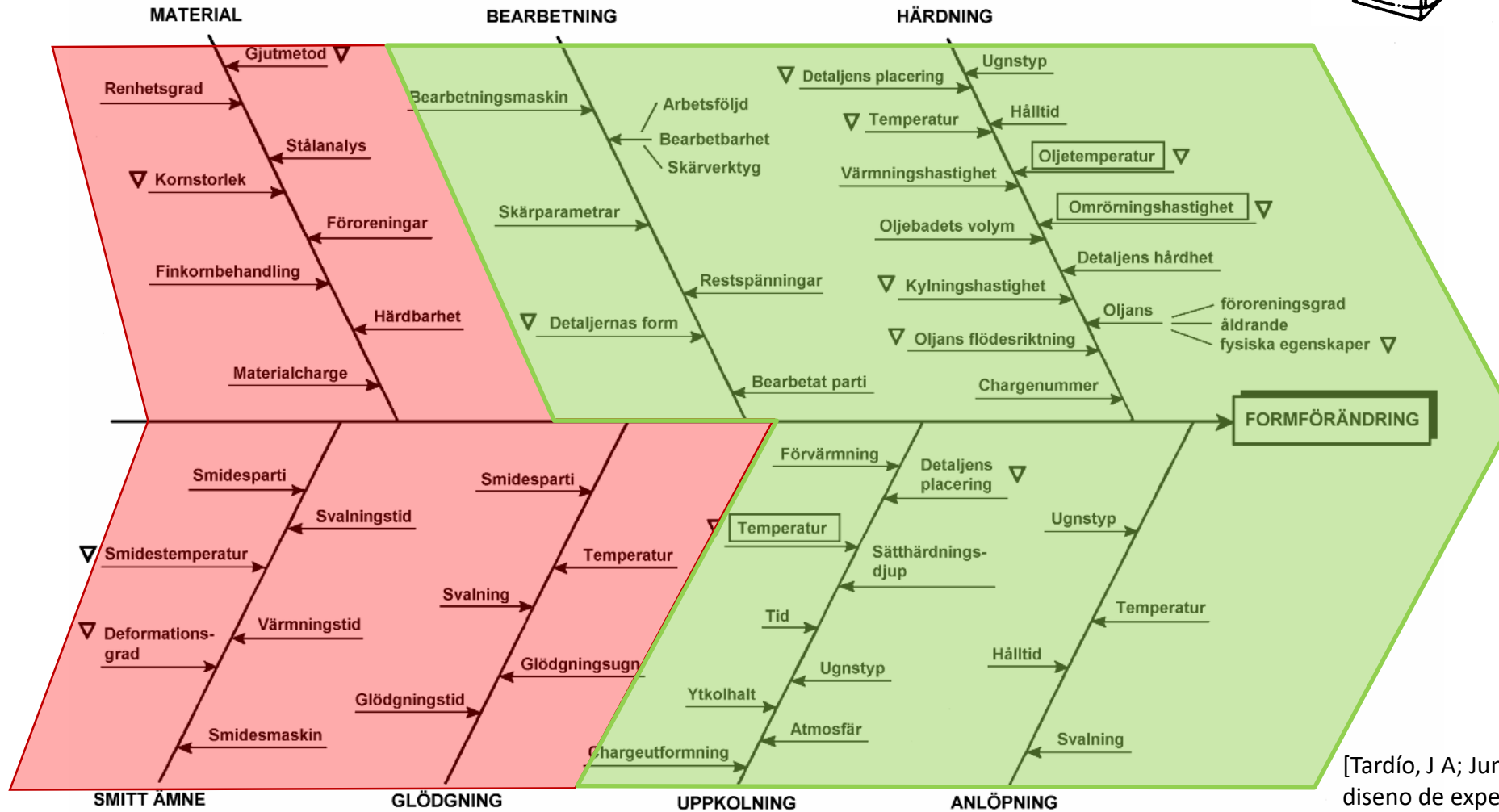
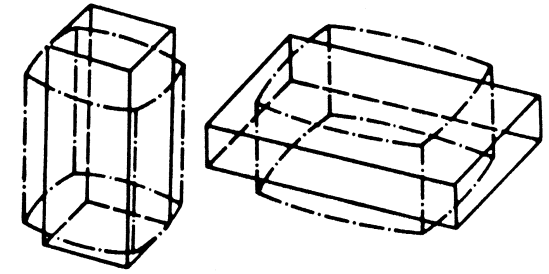

[Tardío, J A; Juncoso, M: Aplicacion del diseno de experimentos. Tratamientos Termicos, dec 1991, p 44-55]

Formförändringar hos kronhjul

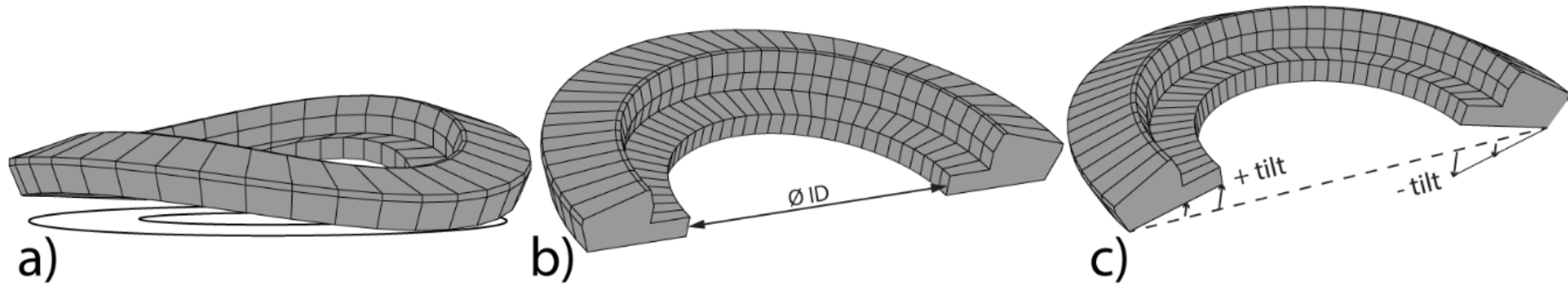

a)

Warp, chipsform
Gear runout
rundgångsfel

b)

Inner diameter

c)

Back-face tilt
Bakplanslutning



Paper 1

A. Olofsson, S. Jonsson, B. Brash, “Hardening Distortions Related to Segregations in Crown Wheels / Härteverzug in Relation zu Seigerungen in Tellerrädern”, *HTM Journal of Heat Treatment and Materials*, 71 (2016) 68-74. doi: 10.3139/105.110282

Paper 2

A. Olofsson, S. Jonsson, “Hardening Distortions of Serial Produced Crown Wheels”, *Mat.-wiss. u. Werkstofftech.* 2017, 48, 862-875

Paper 3

A. Olofsson, M. Köhn, S. Jonsson, “Identifying process parameters influencing gear runout”, Accepted for publication with minor revisions in *Mat.-wiss. u. Werkstofftech*



Material för kronhjul

Steel grade	C	Si	Mn	P	S	Cr	Mo	Ni	Cu	Al	N
17NiCrMoS6-4	0.14	0.14	0.60	<0.035	<0.035	0.80	0.15	1.20	<0.35	<0.05	0.005
	0.20	0.20	0.90			1.10	0.25	1.50			0.015

Tillverkningskedja

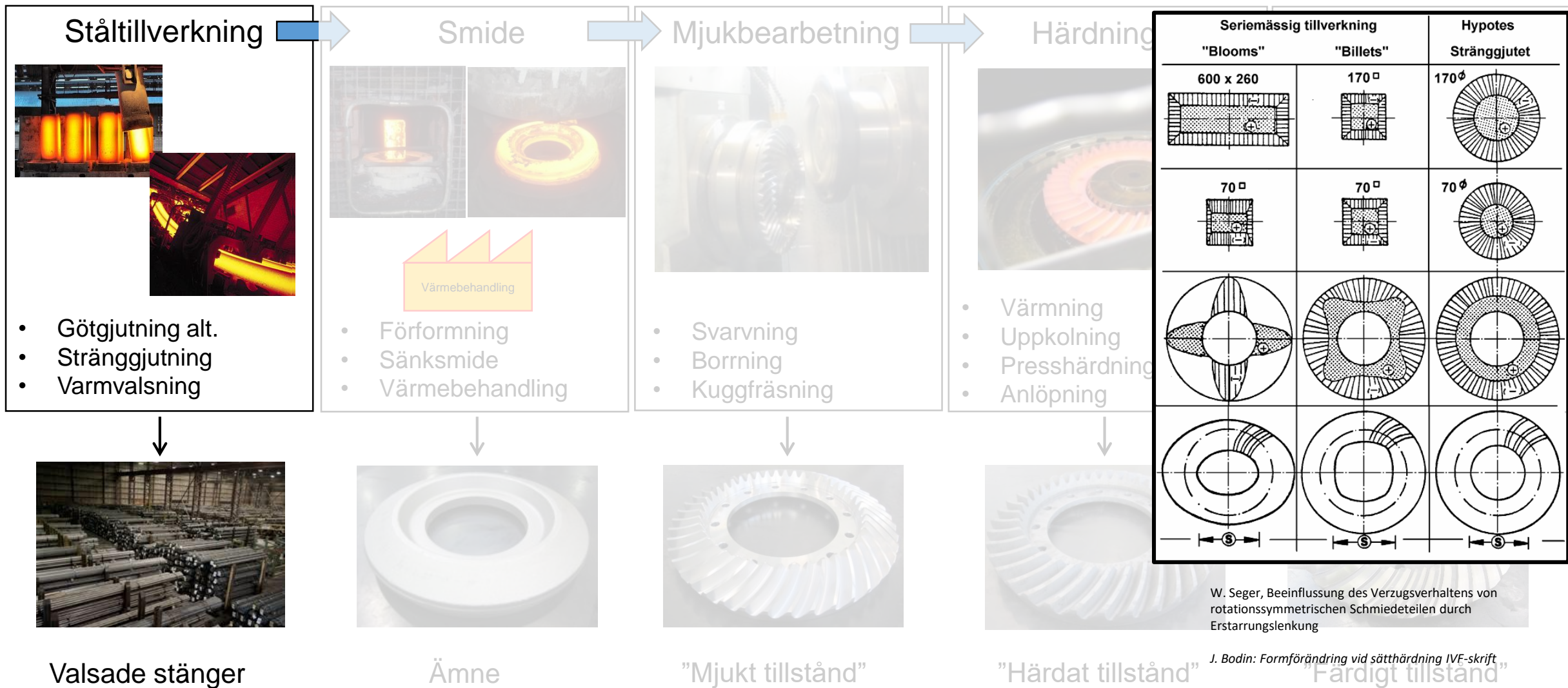

Sätthärdningsprocessen

Pusherugn flöde

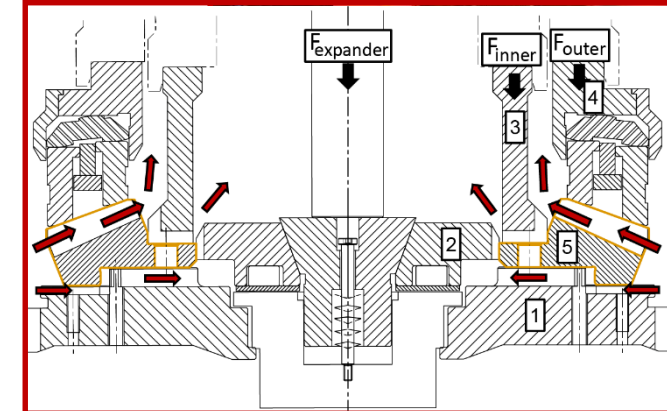
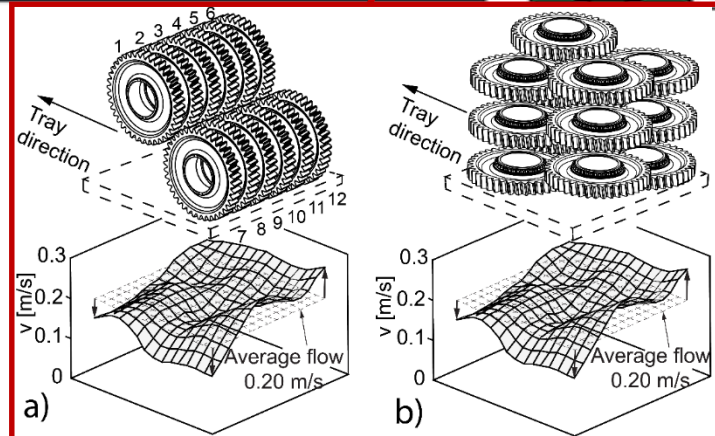
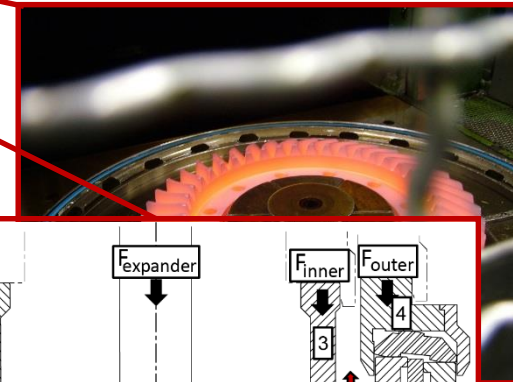
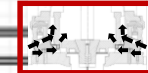
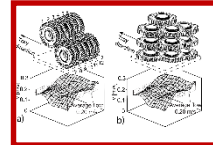
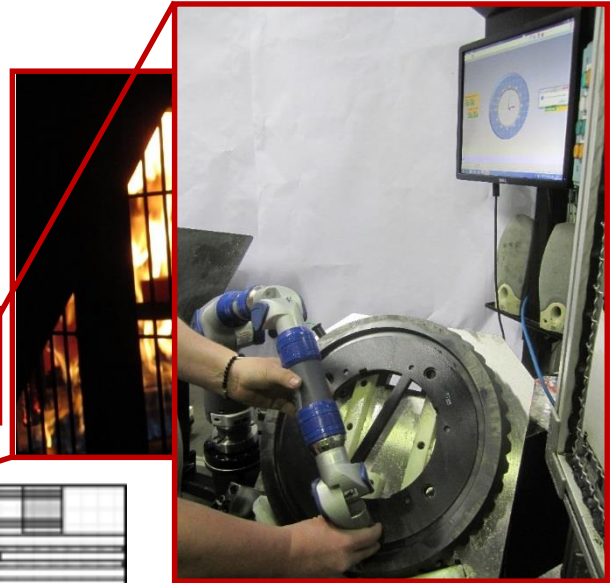
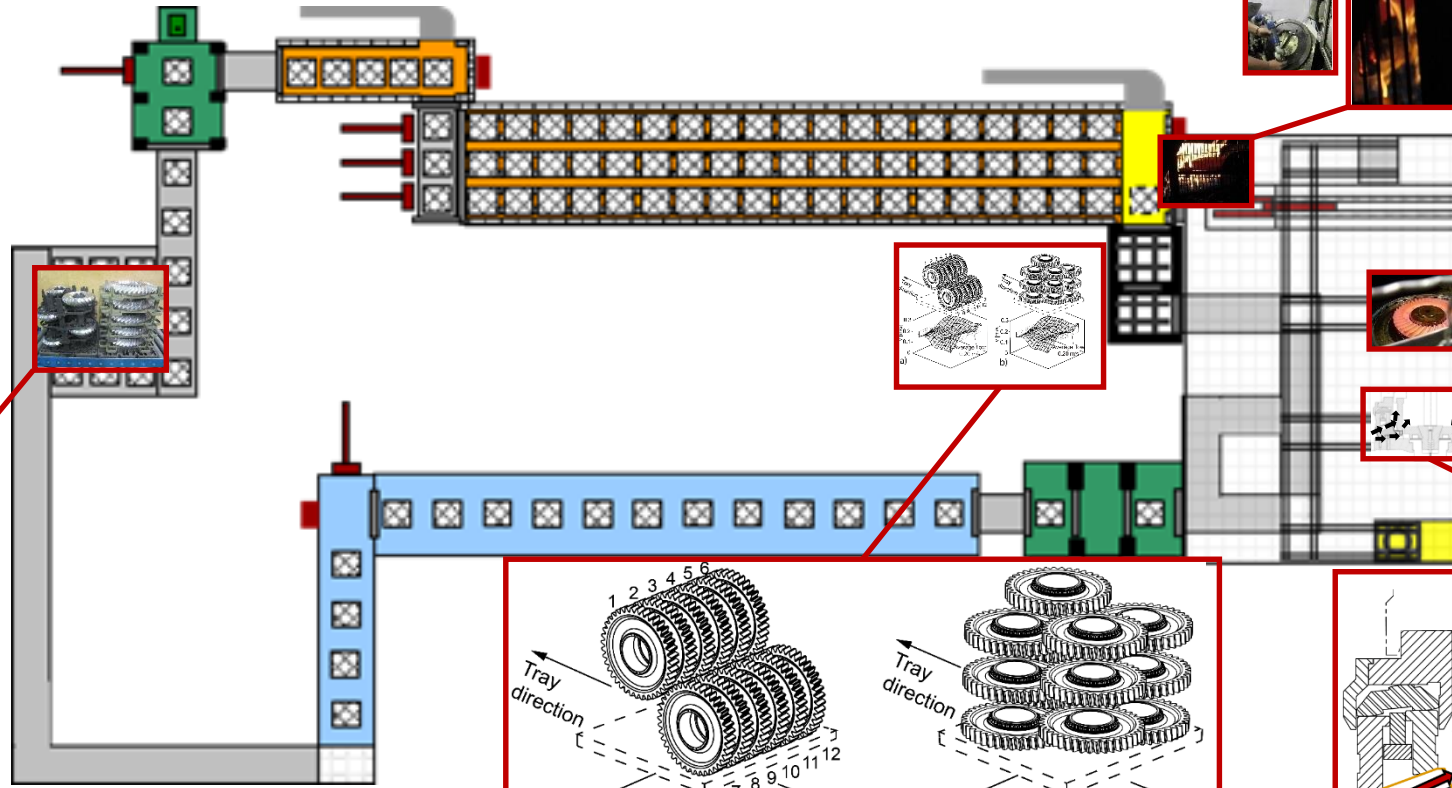

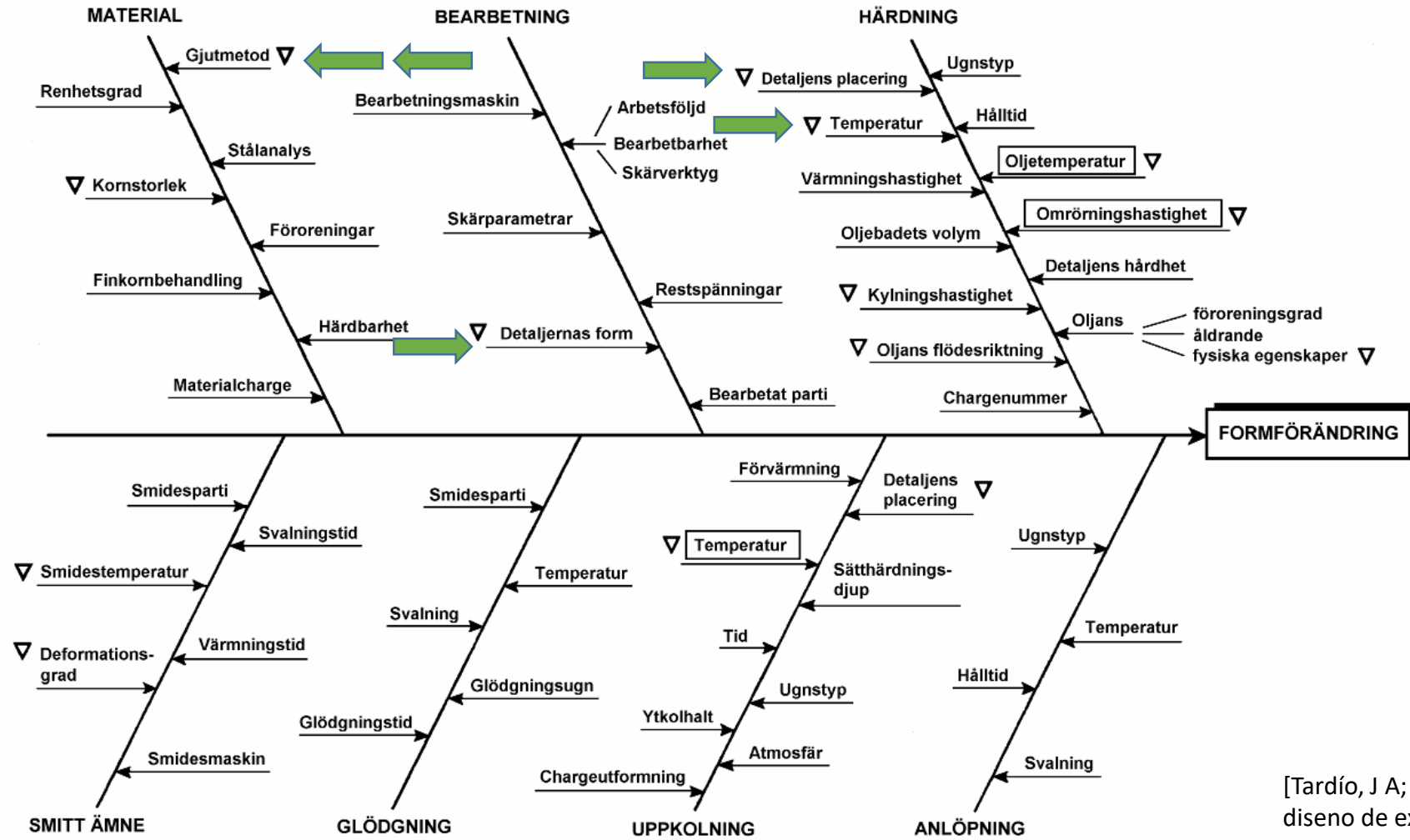

[Tardío, J A; Juncoso, M: Aplicacion del diseno de experimentos. Tratamientos Termicos, dec 1991, p 44-55]

Formförändringar kronhjul

Stålverk

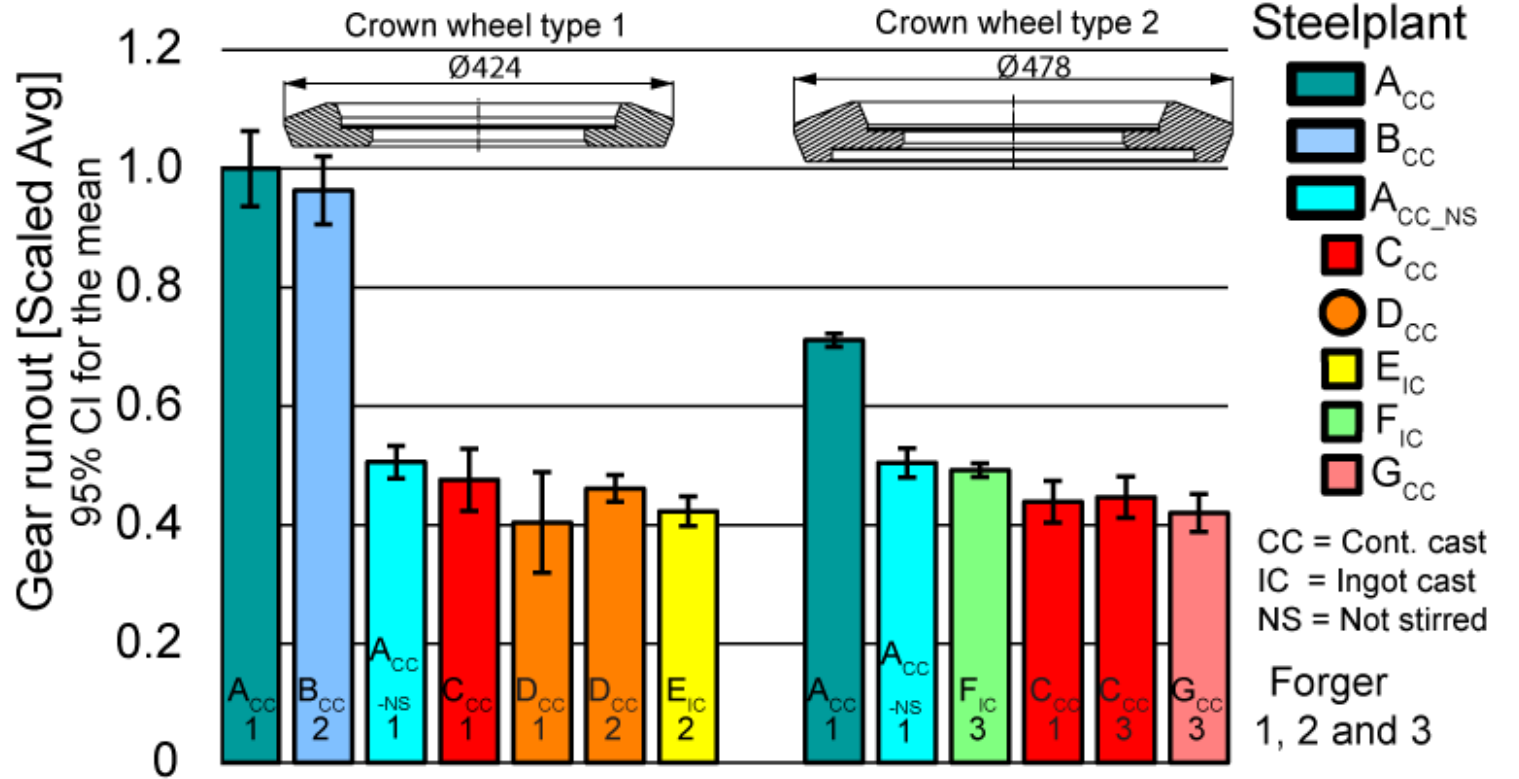
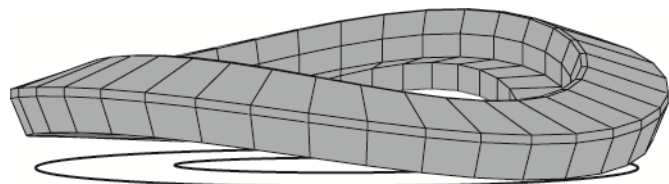
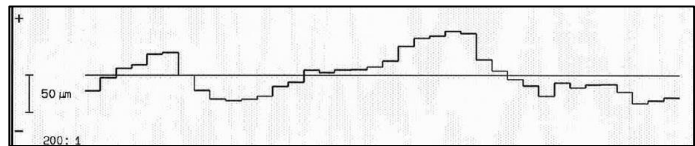

Formförändringar kronhjul

Stålverk och kronhjulsgometri

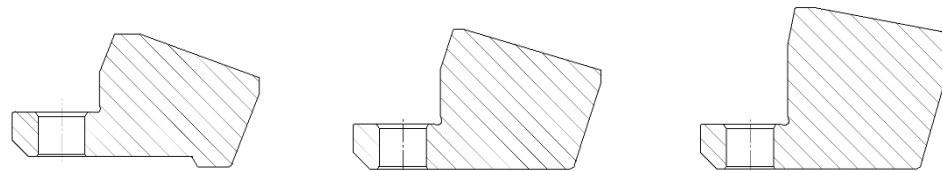
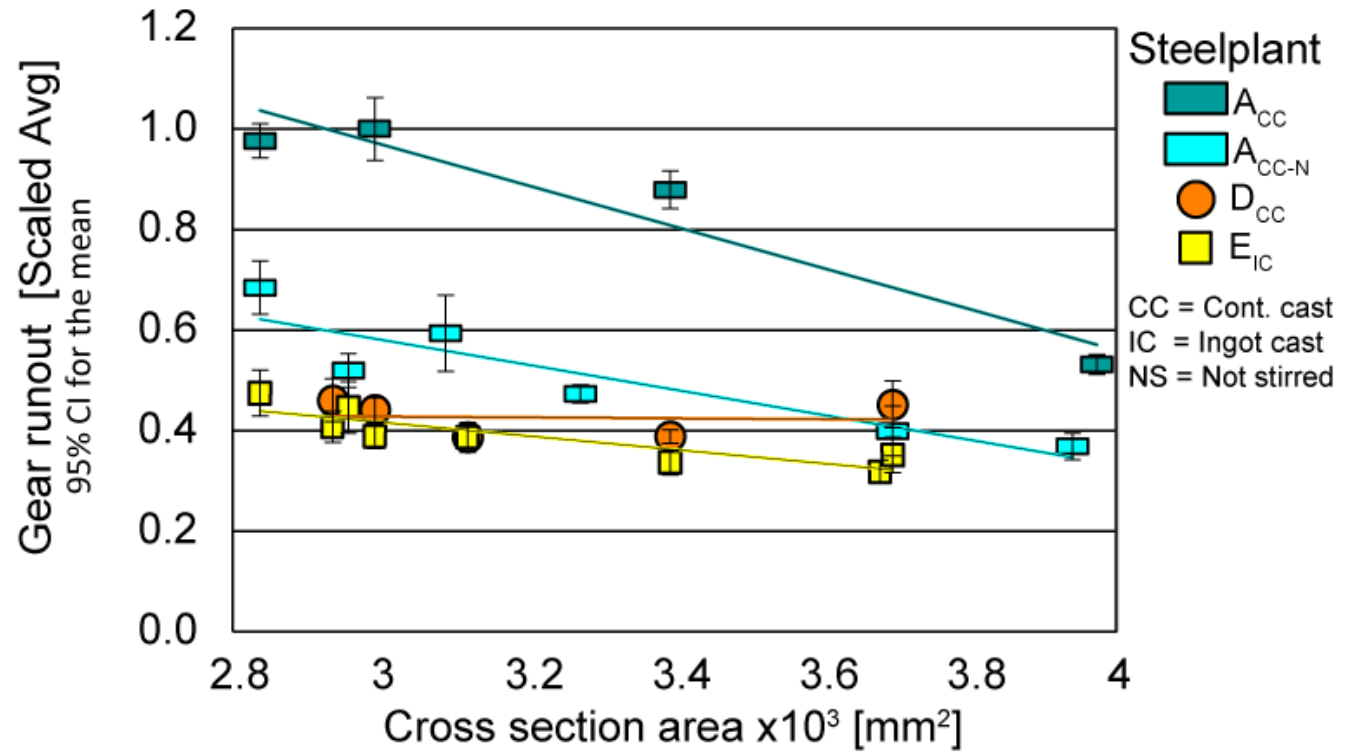
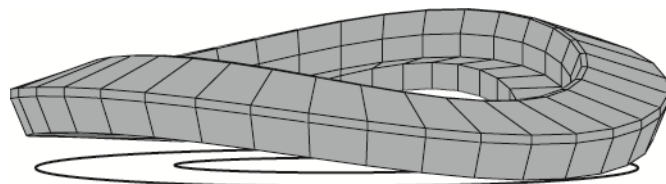
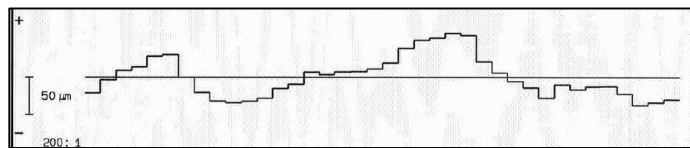

Formförändringar kronhjul

Gjutmetod och kronhjulsgometri

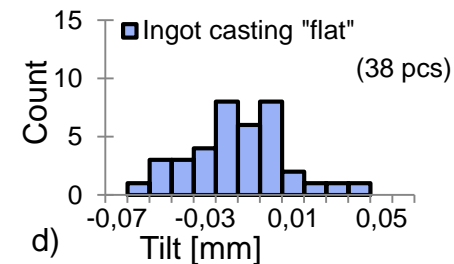
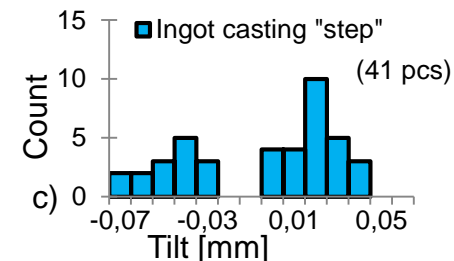
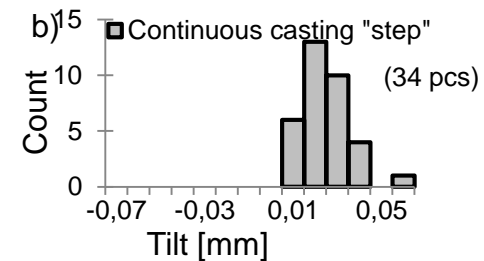
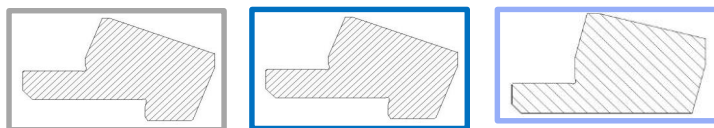
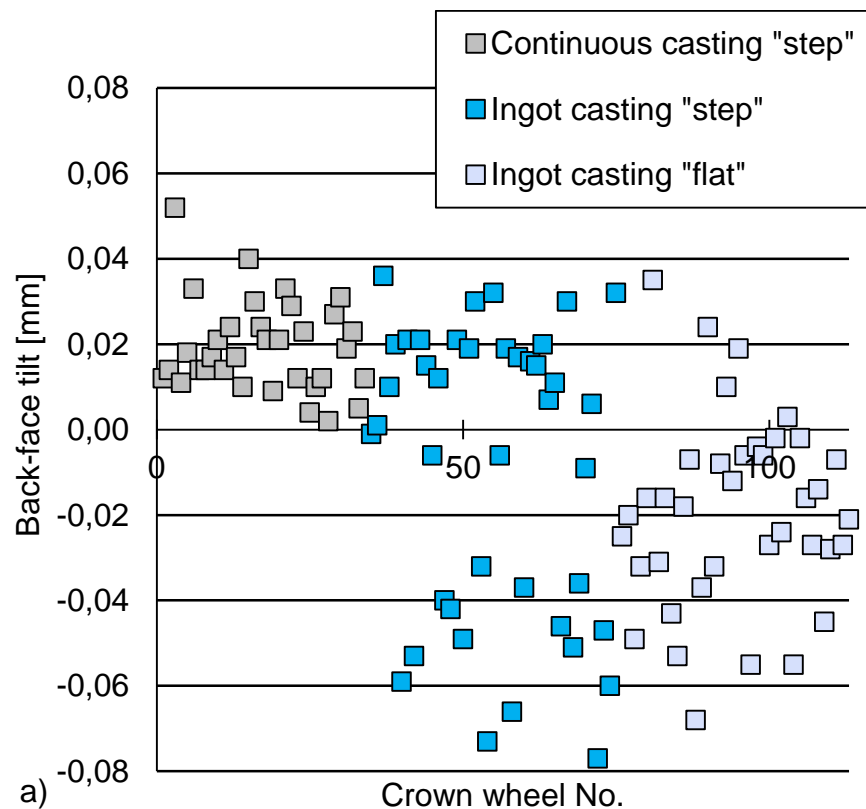
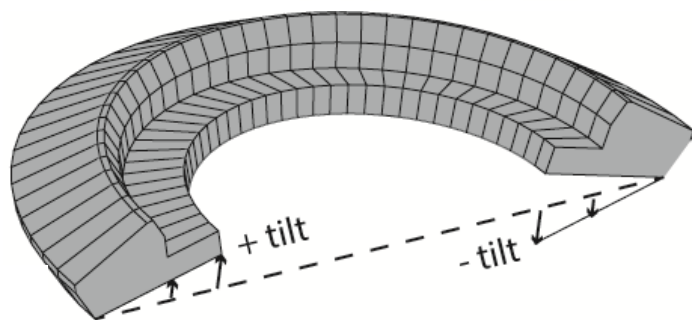
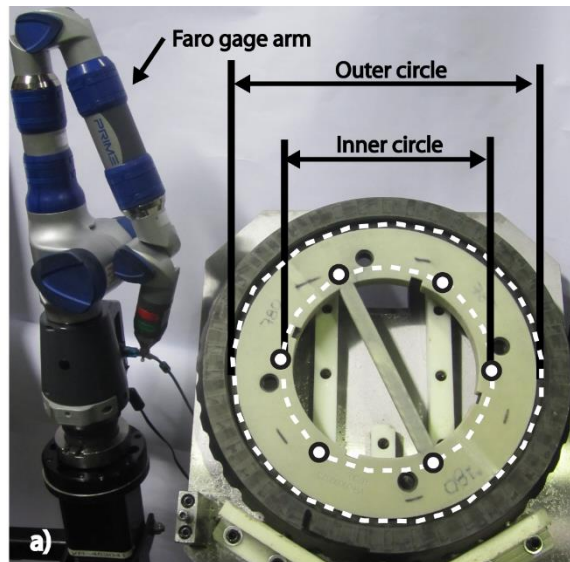

Formförändringar kronhjul

Gjutmetod och kronhjulsgometri

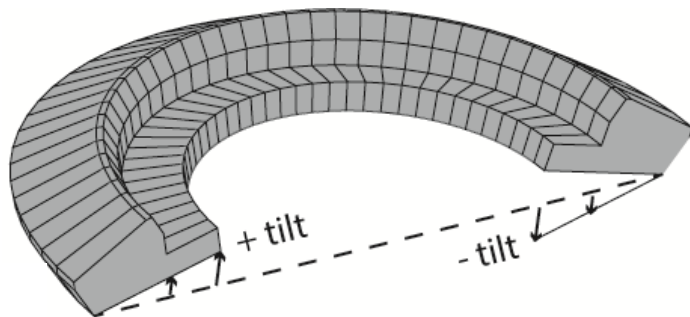
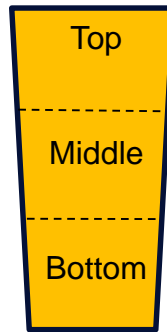

Back-face tilt

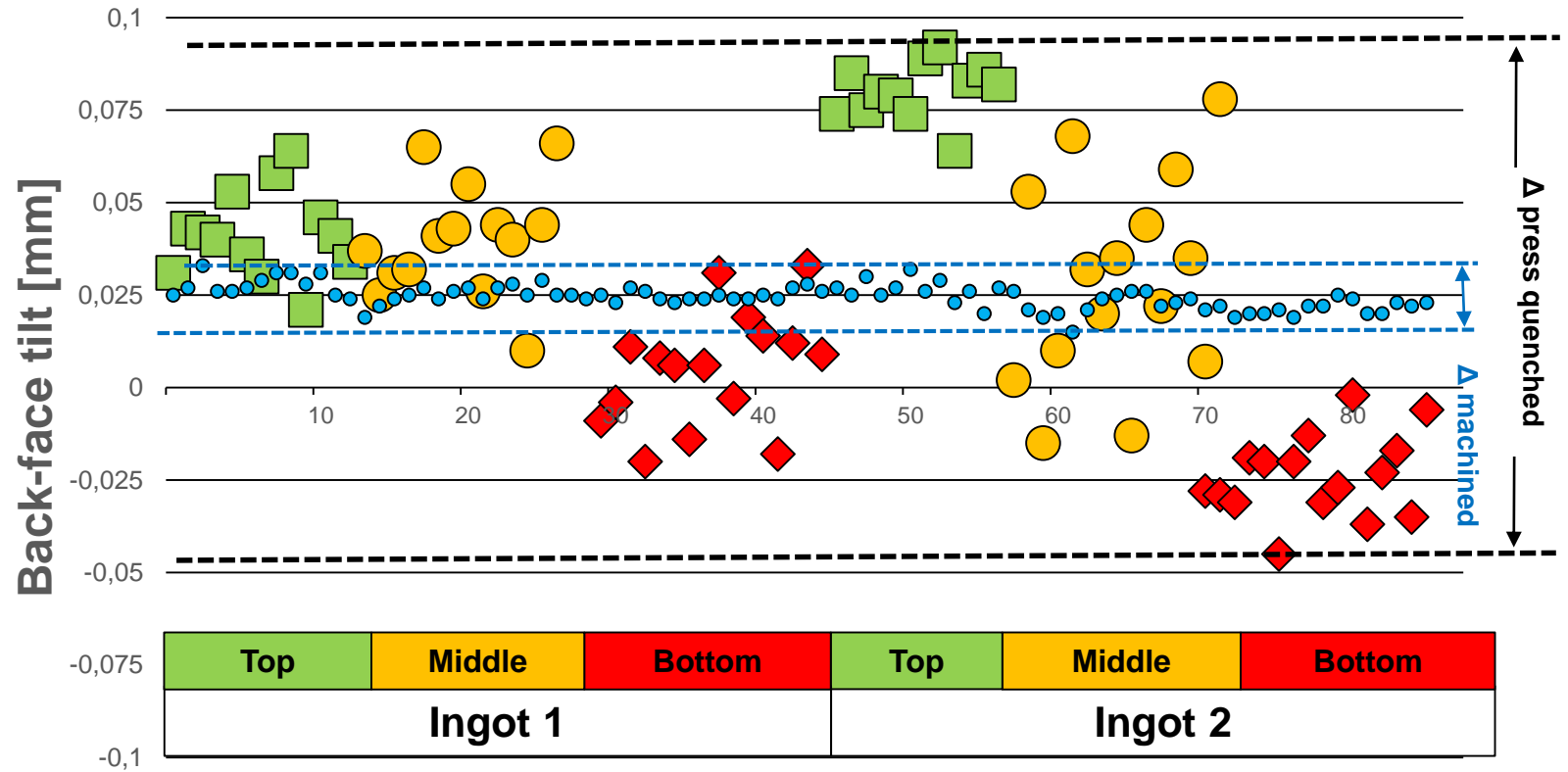

Formförändringar kronhjul

Gjutmetod och kronhjulsgeometri

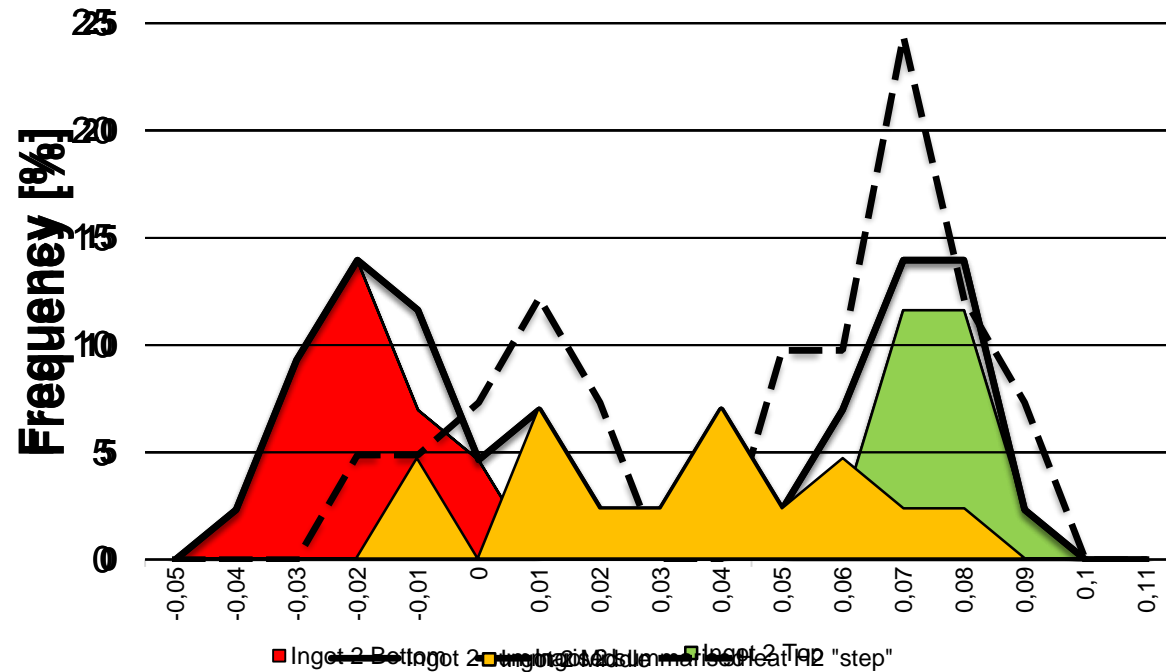
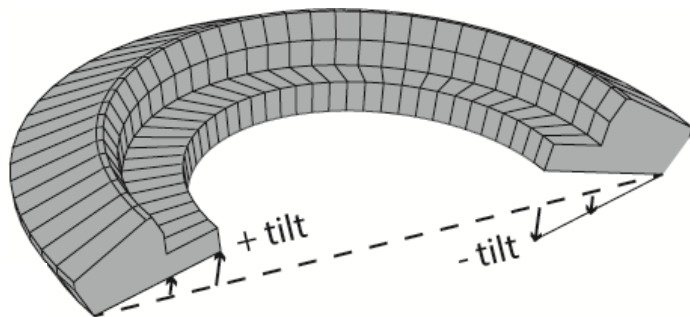
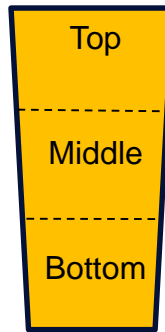
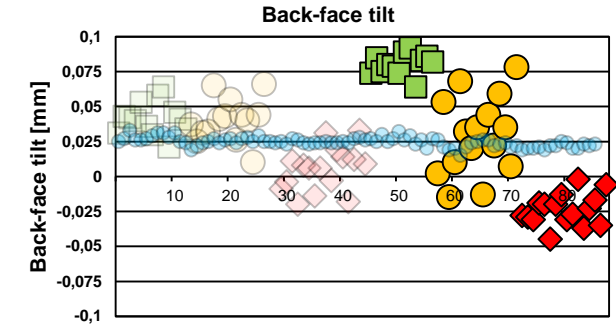

Formförändringar kronhjul

Gjutmetod och kronhjulsgometri

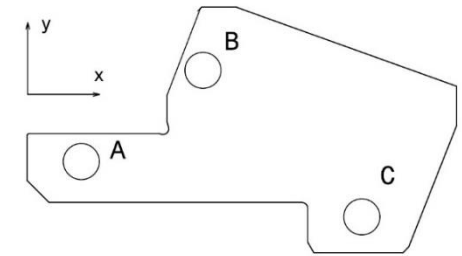
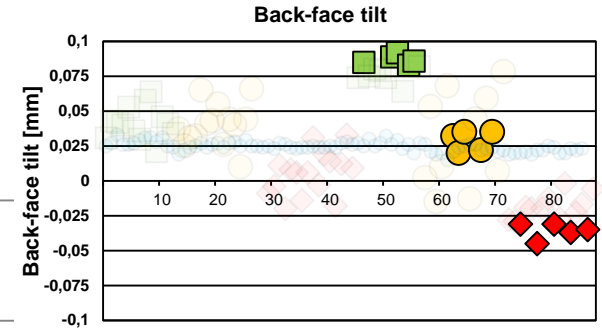
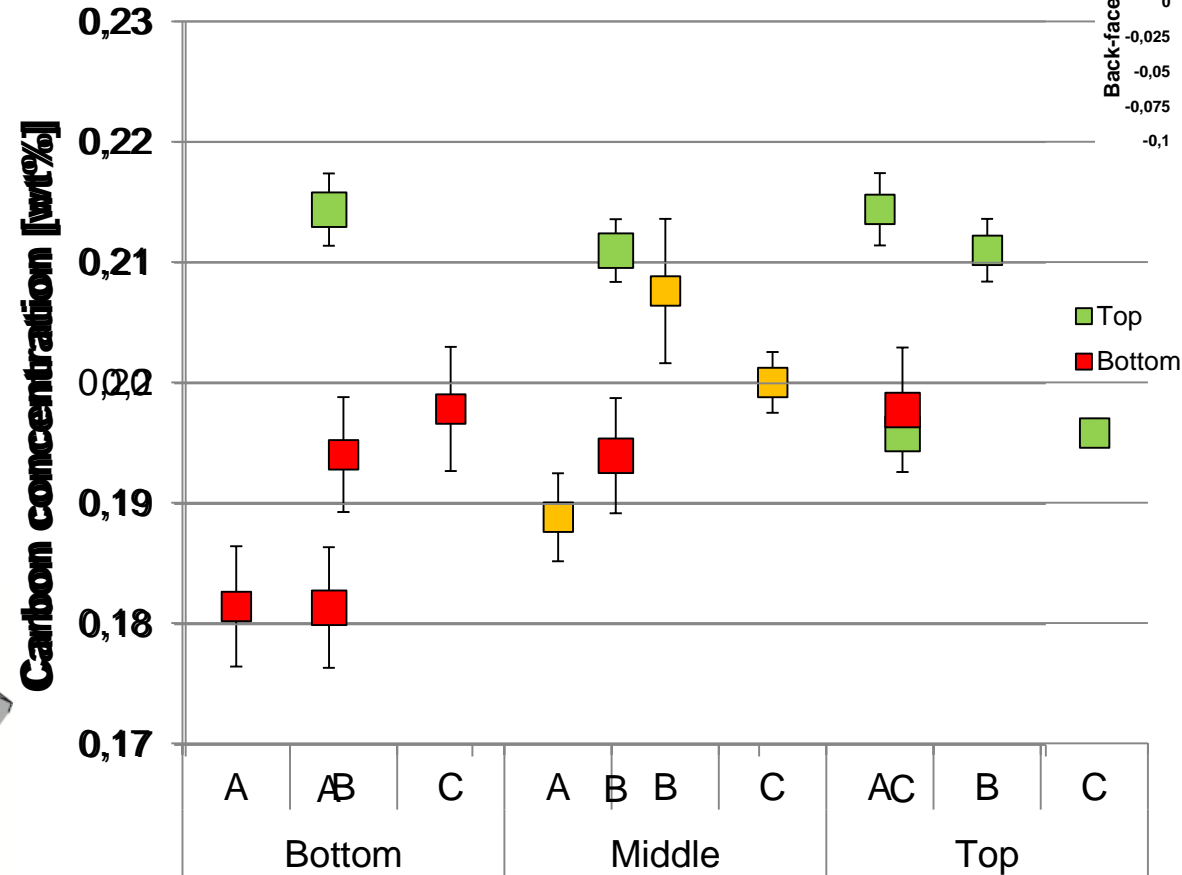
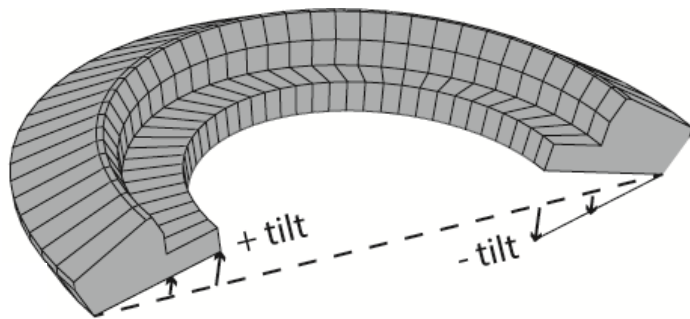
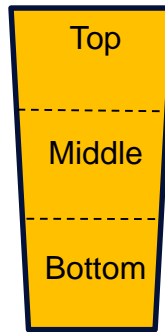



Inverkan av våning på bakplanslutning (med steg)

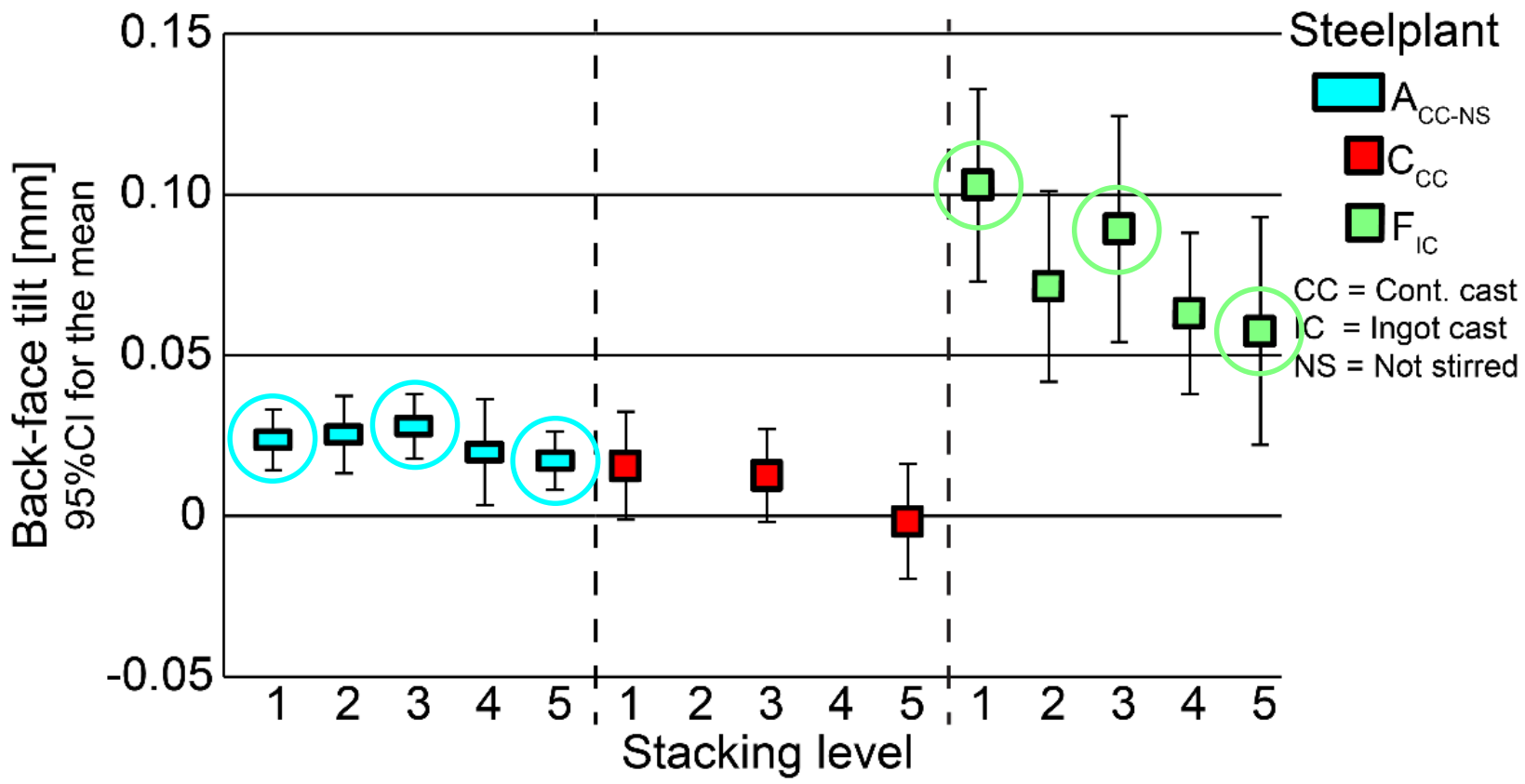
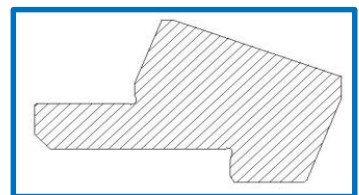
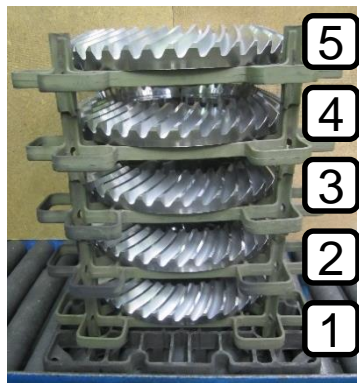



Inverkan av våning och position i götet på bakplanslutning (med steg)

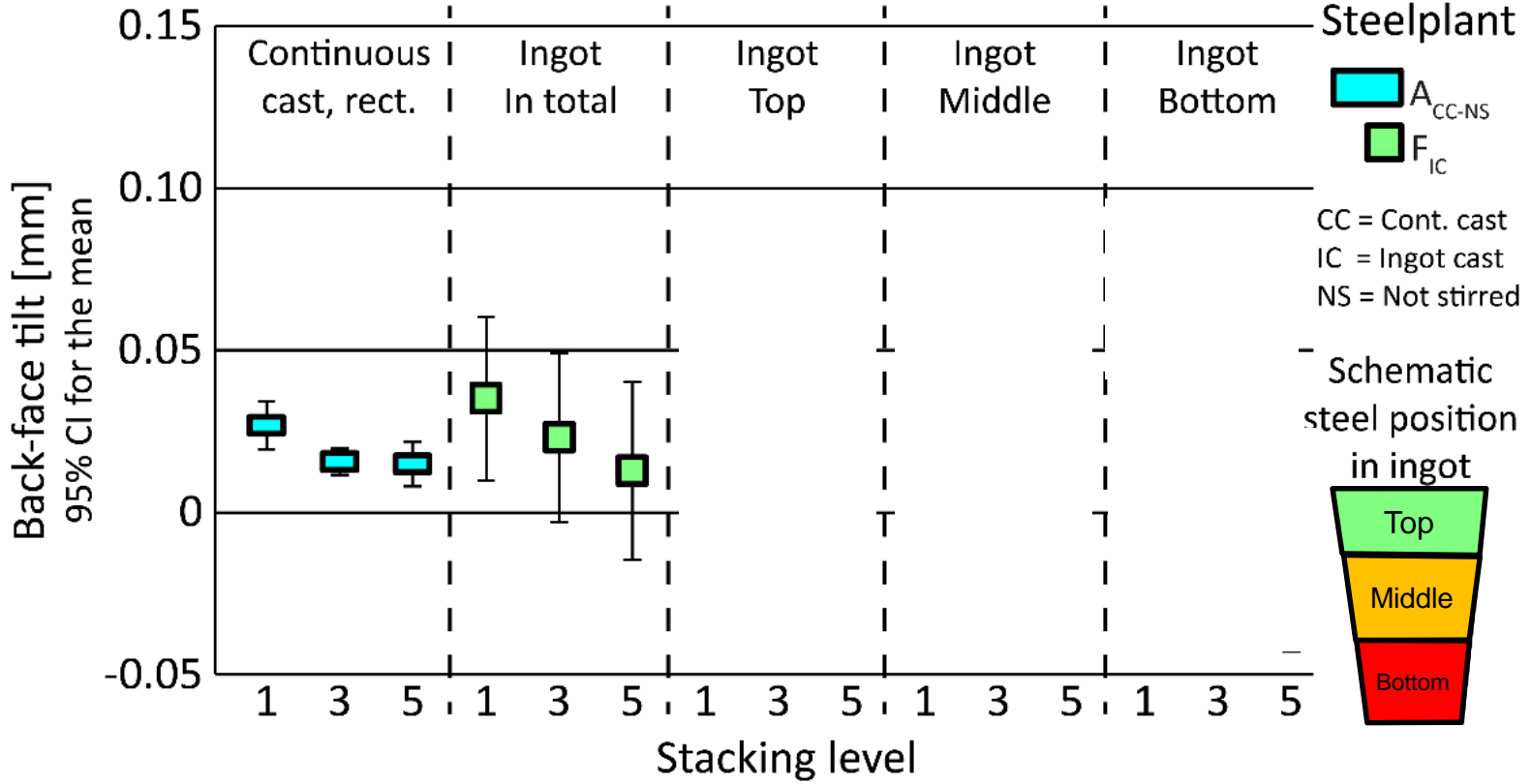

Formförändringar kronhjul

Inverkan av våning

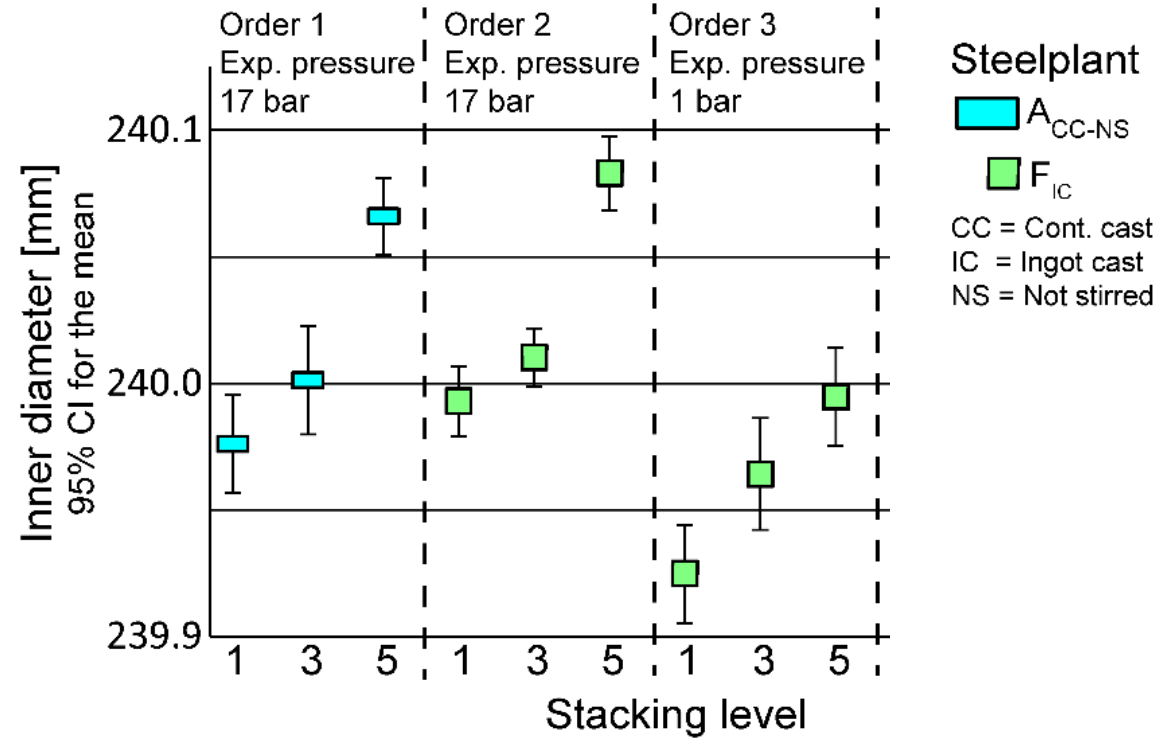
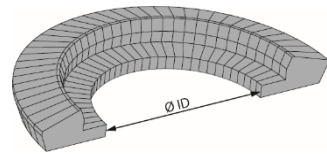
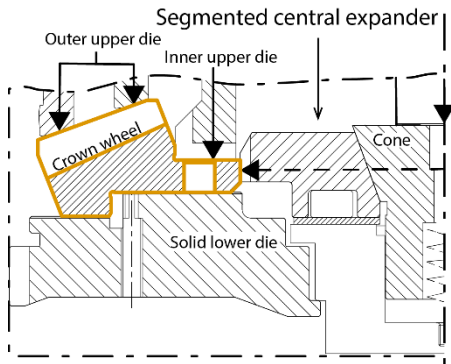
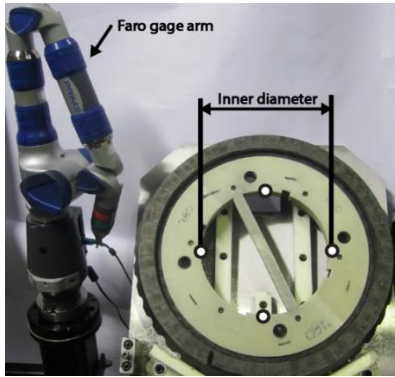

Formförändringar kronhjul

Inverkan av våning

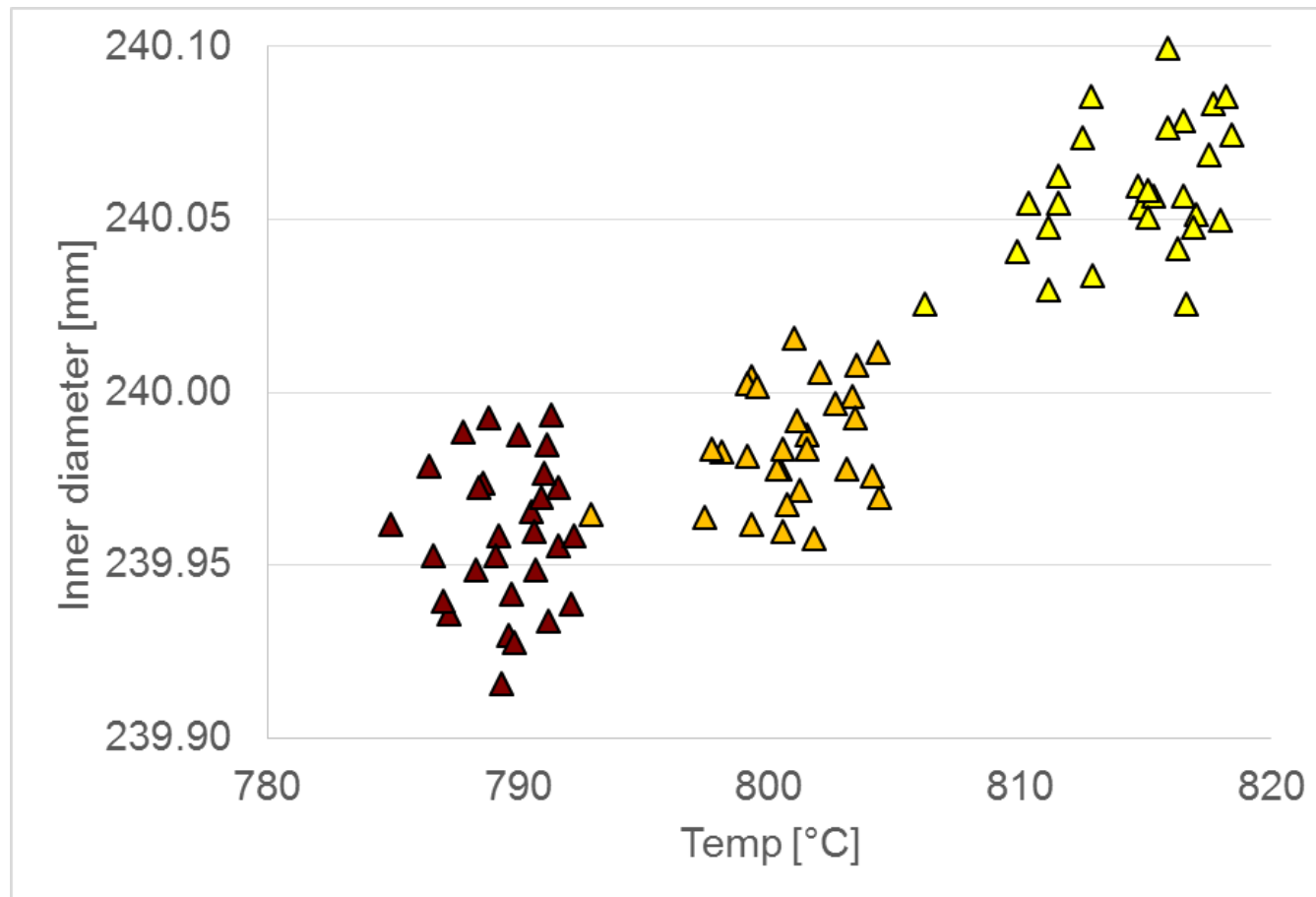
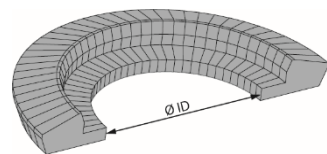
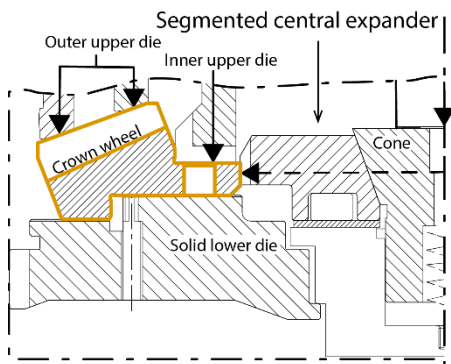
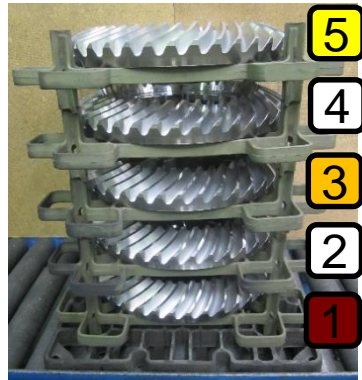
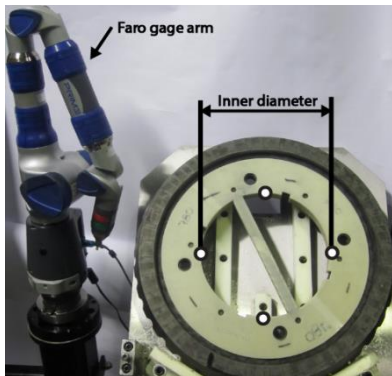

Formförändringar kronhjul

Inverkan av våning

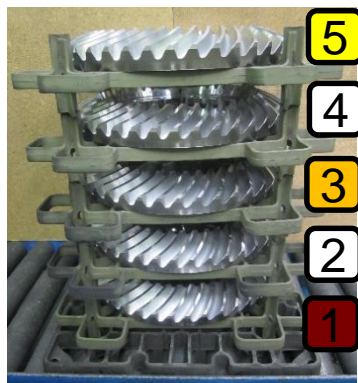

- Lucköppningar
- Härdas en och en
- Likadant oljeföde för varje kronhjul
- Temperaturskillnader mellan våningar!



- Inga lucköppningar
- Härdas samtidigt
- "Individuellt" oljeflöde
- Temperaturskillnader mellan våningar?

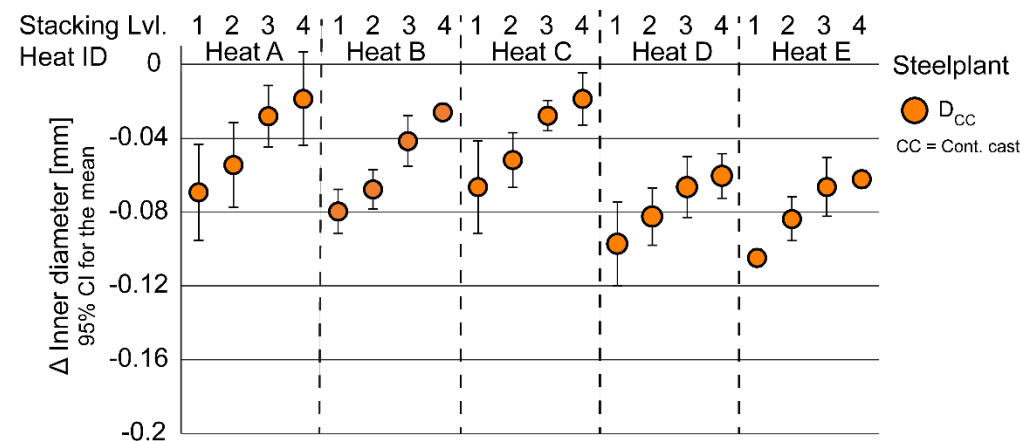
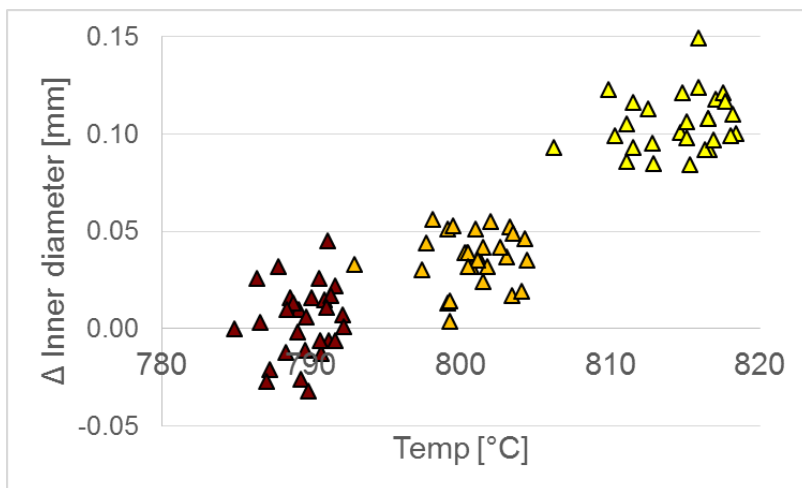

Formförändringar kronhjul

Inverkan av våning

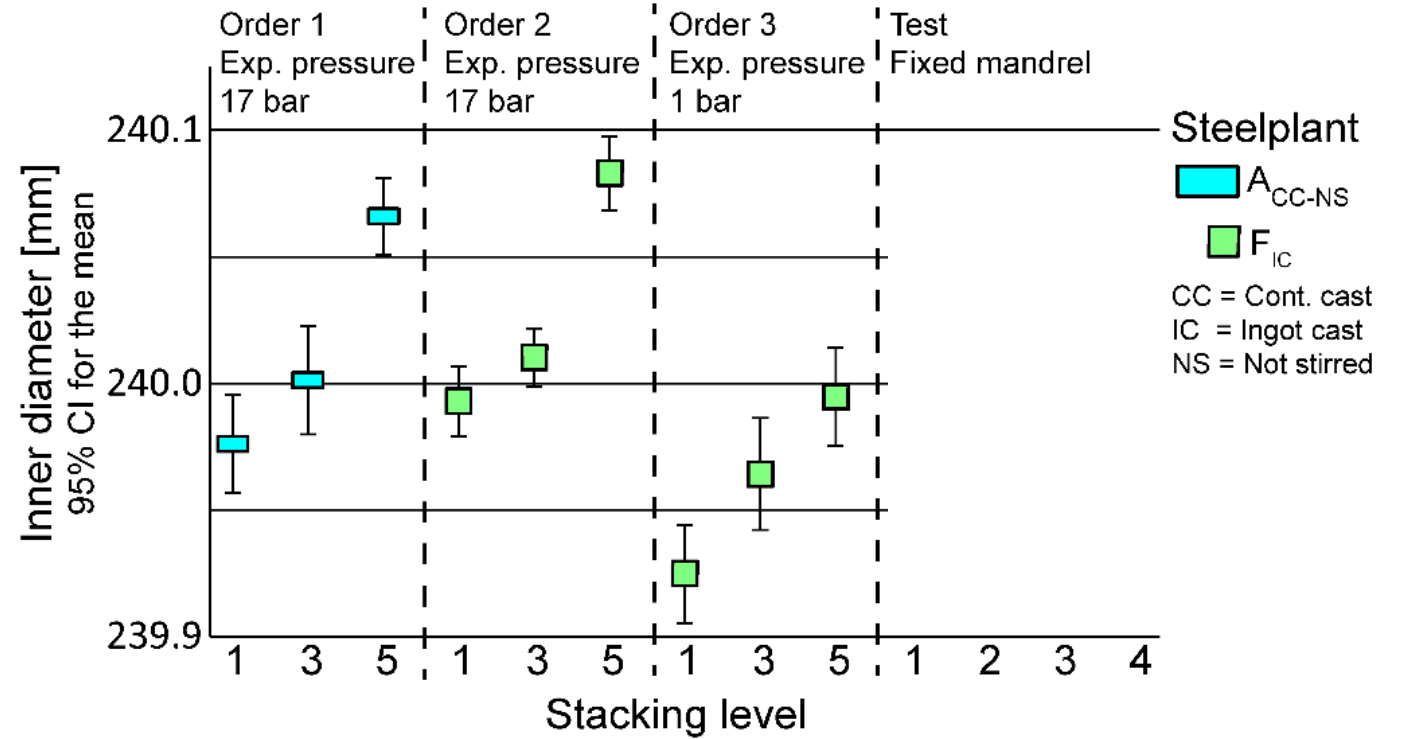
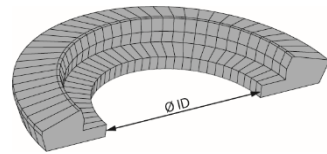
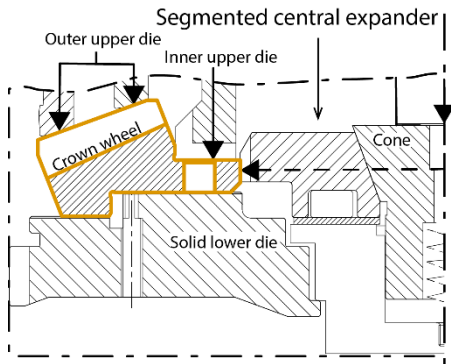
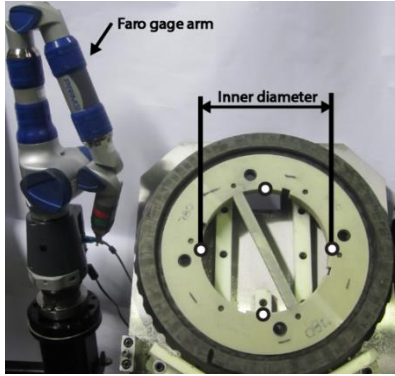

Faktorer som signifikant påverkar formförändringar

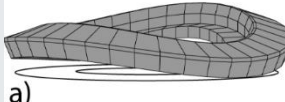
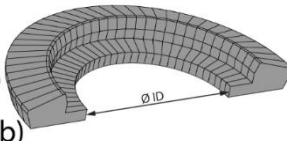
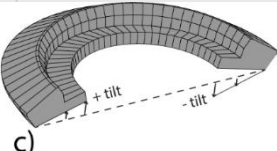
FACTORS	LEVELS	DISTORTION PARAMETERS		
		 a)	 b)	 c)
		Runout	Inner Ø	B-F tilt
Casting method	Ingot casting; top, middle, bottom Continuous casting	CC/CC-NS		X
Casting geometry	Rectangular / Round / Square	X		
Forger	No. 1 / No. 2 / No. 3			
Loading arrangement	Stacking level		X	X
Component geometry	Thin / Thick	X		
	Step / Flat			X

Slutsatser

Material



Process

